

# 2000 GOVERNORS INDUSTRIAL SAFETY & HEALTH CONFERENCE - FORKLIFT RODEO

## REGIONAL DRIVING COURSE

### DRIVING INSTRUCTIONS

(complete driving instructions on reverse)

- - - - - = **DRIVE IN REVERSE** . . . . .  
from start to position #1-  
complete task.
- - - - - = **DRIVE FORWARD** . . . . .  
from position #1, to  
position #2-complete task.  
from position #2 to  
position #3-complete task.  
from position #3 to  
position #4-complete task.  
from position #4 to  
position #5-complete task.  
from position #5 back to  
position #1-complete task.
- - - - - = **DRIVE FORWARD** . . . . .  
from position #1 to finish.

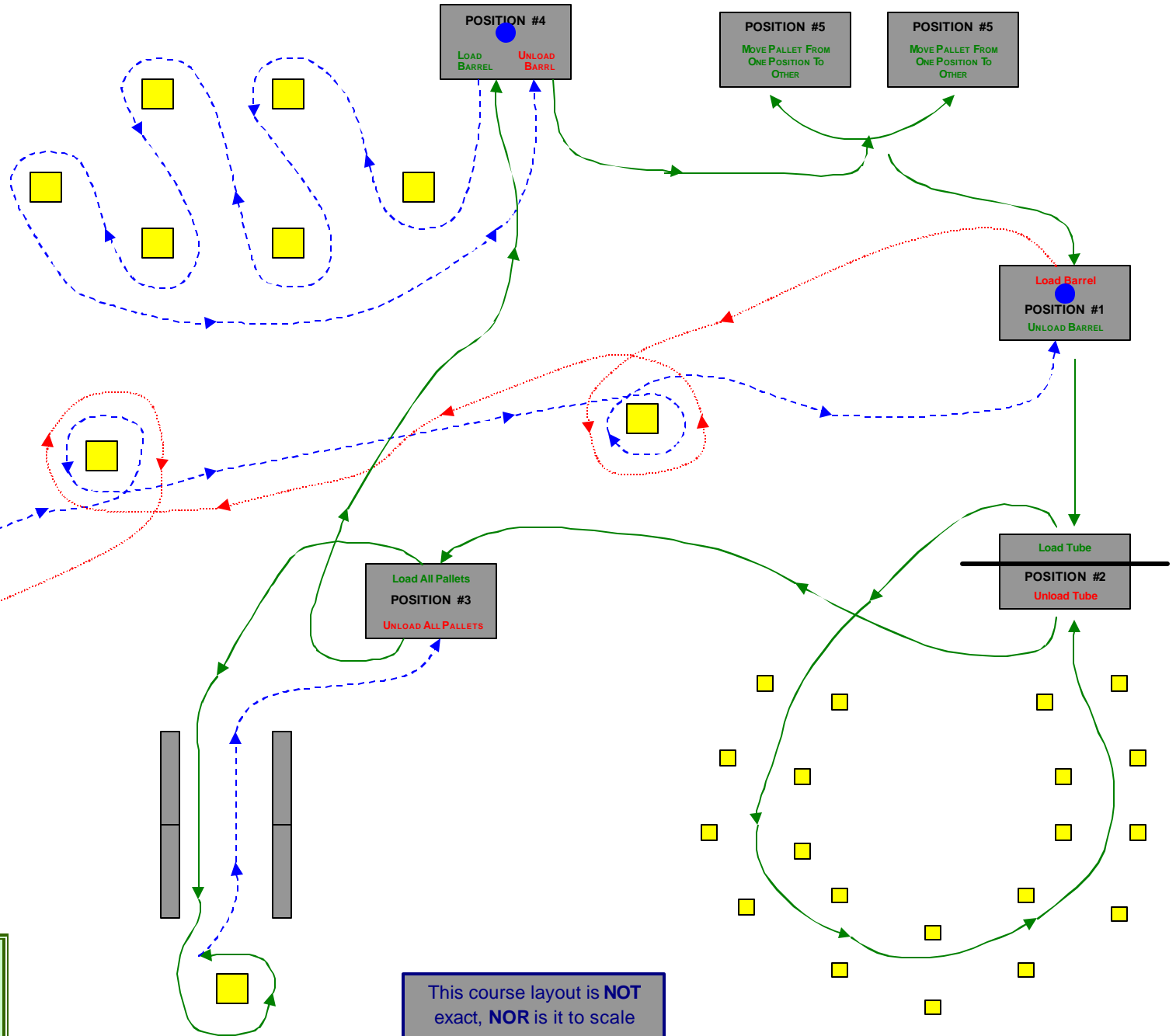
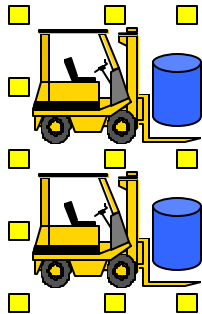

**FOR SAFETY  
SEAT BELT SHALL BE WORN  
WHILE DRIVING THIS COURSE**

This course layout is **NOT**  
exact, **NOR** is it to scale

## 2000 REGIONAL COMPETITION - DRIVING INSTRUCTIONS

START/FINISH area has two positions. Drivers will alternate positions. When one driver finishes the course & judges are completing that driver's evaluation form, the next driver will immediately start with another set of judges.

You will start with a load. You will be given the OK to start engine by starter. Starter will ask "Are you ready to drive?" You will indicate YES or NO. If YES, starter will check if seat belt is secured. If not fastened, you will be reminded to secure it. (You will lose points) Starter will say "GO". Your time will begin when the forklift begins moving.

Drive in REVERSE around the two cones to position #1 & unload the pallet & barrel.

Drive FORWARD to position #2 & load only the long tube – travel FORWARD thru the cones & then place the tube in it's original position.

Move FORWARD to position #3, load pallets (leave bottom pallet).

Drive FORWARD thru the obstacle & around cone, then . . . . .

Drive in REVERSE back thru the obstacle & replace the pallets in their original position.

Move FORWARD to position #4, load only the pallet w/barrel.

Drive in REVERSE thru obstacles & return barrel to original position.

Travel FORWARD to position #5 & move all pallets from one position to the other.

Move FORWARD to position #1 & load the pallet & barrel.

Travel FORWARD around both cones to start/finish.

### NOTE:

*TIME WILL NOT STOP UNTIL YOU HAVE PROPERLY PARKED, LOWERED LOAD AND SET PARKING BRAKE.*

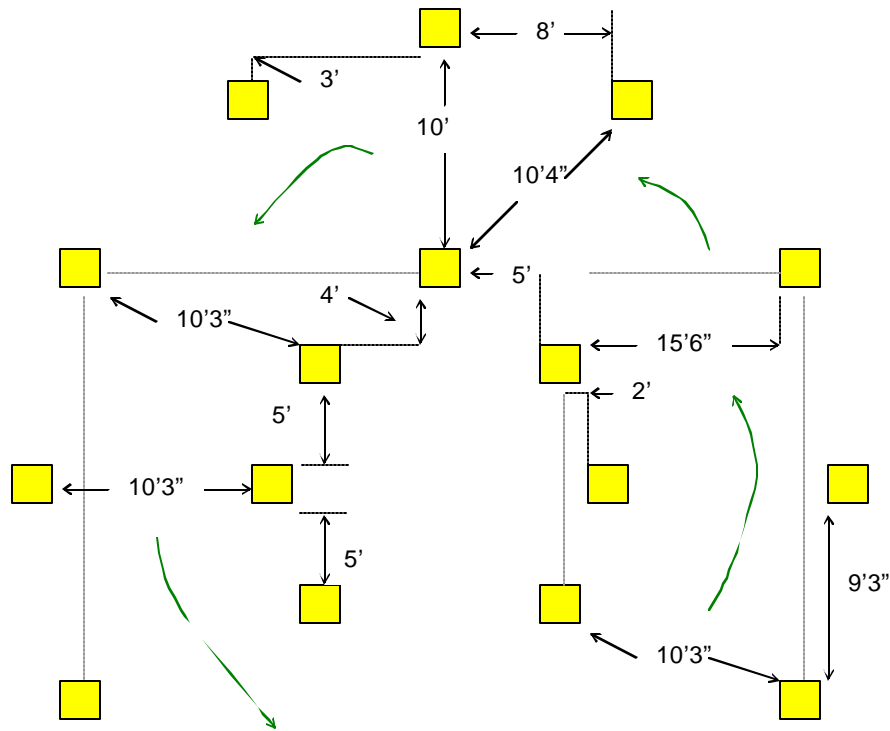

**COURSE LAYOUT FOR USING  
DOWNSPOUT PROP (2 SECTIONS)  
(USING 16 SMALL CONES)**

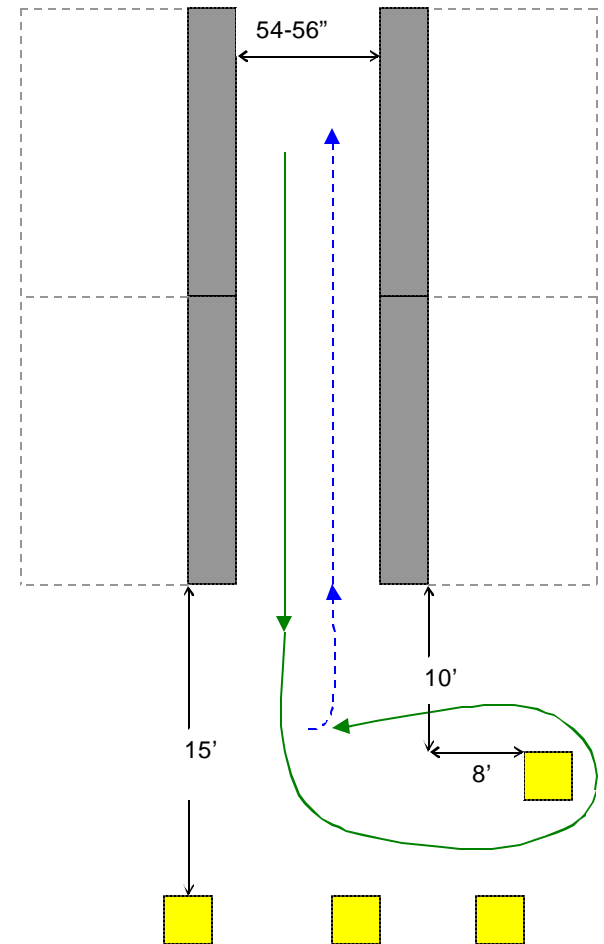

**COURSE LAYOUT FOR 'TUNNEL' PROP  
USING LARGE CONES  
(USE PALLETS ON EDGE OR  
SEVERAL STACKED UP)**

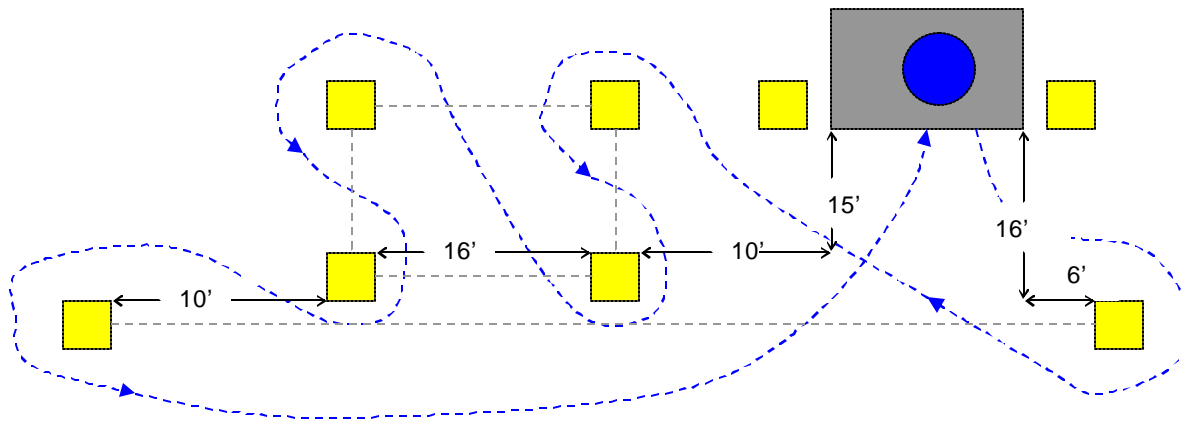

**COURSE LAYOUT FOR THIS PROP (USED BARREL)**